



Transmission Lines Electricity's Highways

W.O. (Bill) Kennedy, P.Eng., FEIC
Principal



Introduction

- Transmission lines are the highways for electricity.
- Their main purpose is to connect load to generation.
- Electricity in the context that I'll use it includes both power and energy.
- Transmission lines are a civil, mechanical and electrical engineering challenge.
- This talk will focus on the electrical aspects of transmission lines.



Transmission lines

- For the power system, there are all types of transmission lines from low voltage to high voltage.
- Each has its own purpose and each has a fixed amount of electricity transfer capability.
- Transmission lines are complex devices influenced by system voltages, loading, physical properties, system reactive capability and stability.
- We'll examine each of these.
- We will start with Surge Impedance Loading (SIL).
- SIL is an important property of transmission lines.



SURGE IMPEDANCE LOADING



Surge Impedance Loading (SIL)

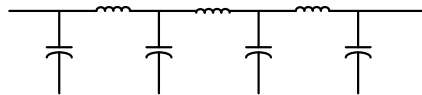

- Transmission line consists of:
 - Shunt capacitance
 - Series resistance and inductance
 - Distributed along length of line
- Treat as distributed lumped elements
- Can ignore resistance

© 2013 b7kennedy & Associates Inc.

5



Surge Impedance Loading (SIL)

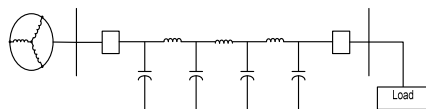
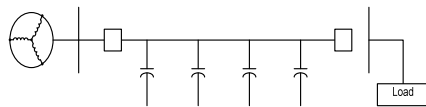

- Close the breaker at sending end
- Shunt capacitance charges to $\frac{1}{2} CV^2$
- Close the breaker at receiving end and feed the load
- Series inductance consumes energy at $\frac{1}{2} LI^2$

© 2013 b7kennedy & Associates Inc.

6



Surge Impedance Loading (SIL)

Equating shunt and series energies

$$\frac{1}{2} CV^2 = \frac{1}{2} LI^2$$

Performing the math yields

$$SI = \frac{V}{I} = \sqrt{\frac{L}{C}}$$

$$\text{SIL (power)} = V^2/SI$$



System Model

- We need to develop a system model.
- We will assume two machines at each end of our line.
- Each machine will have sufficient reactive power capability to supply and absorb the reactive power from/to the line.
- We know we can 'collapse' any power system to a two machine equivalent.
- Effectively, we're developing a Thévenin voltage behind a Thévenin impedance.
- For the Thévenin impedance, we'll use the breaker's three phase fault rating.



System Model

- There are three line models.
- The first is the open circuit line. That is, how does a transmission line open circuited at the receiving end behave? We'll deal with this briefly.
- The second is the line with active and reactive power sources at both ends. This will be the subject to the seminar.
- The third is the line that has an active and reactive power source at the sending and a load at the receiving end.
- That is, the receiving end has no reactive power generation capability. We will not be discussing this type of line.

© 2013 b7kennedy & Associates Inc.

9



SIL Example

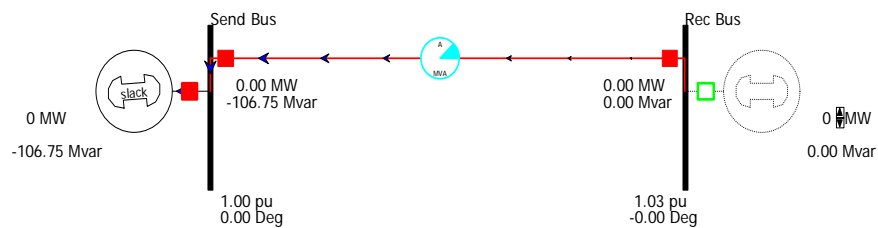

© 2013 b7kennedy & Associates Inc.

10



Properties of Surge Impedance (SI)

- Remains fairly constant over a wide range of voltages.
- Starts around 400 Ω at lower voltages and decreases with bundling to around 225 Ω at 1500 kV.
- Bundling – use of more than one conductor per phase.
- Capacitance and inductance also remain fairly constant.
- Using this, we can construct the following table.
- Conductor size is expressed thousand circular mils or MCM. MCM is an expression of conductor current carrying area.
- Capacitance or charging is expressed as kVAr/km.
- R and X are in Ω /km or ohms/km.



Conductor Bundling

- Bundling is required at higher voltages.
- Bundling is the use of two or more conductors per phase.
- Bundling reduces the series inductance and increases the shunt capacitance.
- The effect is to decrease SI and increase SIL.



Properties of Transmission Lines

Voltage (kV)	Conductor (MCM)	SI (Ω)	R (Ω /km)	X (Ω /km)	Charging (kVAr/km)	SIL (MW)
72	266	390	0.41	0.5	17	13
138	477	386	0.14	0.5	63	49
230 (single)	795	384	0.09	0.5	176	138
230 (bundled)	2x795	281	0.04	0.4	247	188
345 (bundled)	3x795	257	0.03	0.3	605	462
500 (bundled)	4x795	238	0.02	0.3	1,339	1051

© 2013 b7kennedy & Associates Inc.

13



ST. CLAIR CURVE

© 2013 b7kennedy & Associates Inc.

14



St. Clair Curve

- Based on empirical knowledge of 1950's.
- Maximum loading at 50 miles (80 km) 3 x SIL – thermal criteria.
- Maximum loading at 300 miles (480 km) 1 x SIL.
- St. Clair recognized relationship was not linear and drew a curved line between the two points.
- Assumed infinite VAr supply.
- Reasonable for the sending end if a generator is present.
- Not so reasonable for the receiving end if there's no reactive source.
- We'll assume that there's sufficient reactive power at both ends of the transmission line.

© 2013 b7kennedy & Associates Inc.

15

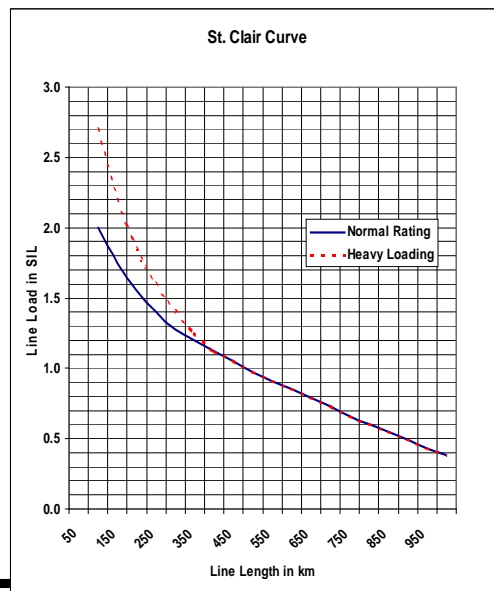

© 2013 b7kennedy & Associates Inc.

16



St. Clair Curve

- Dunlop et al in 1979 supplied analytical development for the St. Clair Curve.
- Up to 50 miles (80 km) loading based on thermal characteristics of the conductor – typically 3 x SIL.
- From 50 (80 km) miles to 200 (320 km) miles, loading dependent on voltage drop.
- Followed a 5% voltage drop criteria. Represents a heavily loaded transmission line.
- Above 200 miles (320 km) loading dependent upon Steady State Stability Limit.
- Set steady state stability limit to 30% (44°).

© 2013 b7kennedy & Associates Inc.

17



Dunlop et al.

- Used a two machine model.
- Assumed fully developed systems, i.e. high short circuit current or low short circuit impedance.
- Purpose was to extend the St. Clair Curve to UHV and line lengths approaching 1,000 km.
- Original St. Clair Curve went to 640 km.
- Set sending and receiving end Thévenin impedances equal to breaker rating (50 kA).
- Assumed infinite VAr supply, same as St. Clair.
- Results – confirmed validity of St. Clair Curve.

© 2013 b7kennedy & Associates Inc.

18



500 kV Example

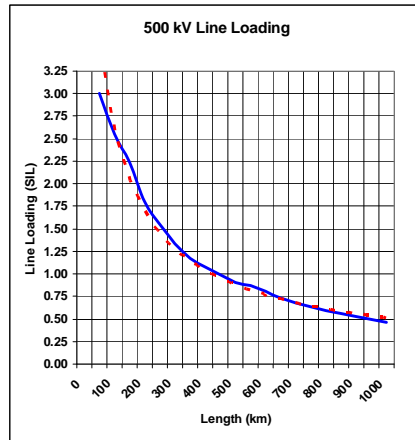

- Red dotted line – trend line.
- For this example, smooth changeover between criteria.
- 500 kV short circuit level = 50 kA.



230 kV Example

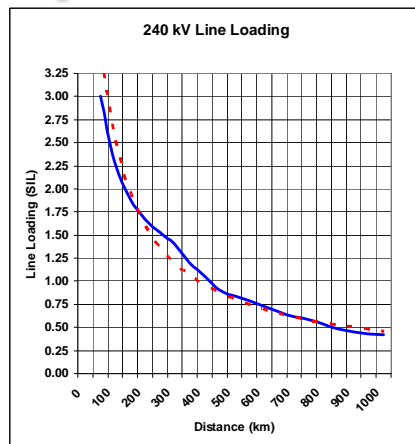

- Red dotted line – trend line
- Demonstrates change over from voltage to angle criteria
- 240 kV system short circuit value = 20 kA



Comparison

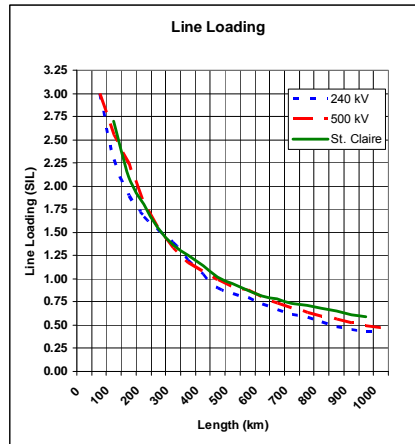

- Good correlation between curves.
- Lower short circuit levels mean lower loading capabilities.
- That is, line loading will lie below St. Clair Curve.



USING THE ST. CLAIR CURVE



Using St. Clair

- Need to supply a 100 MW load 125 km from the nearest source.
- Assume a simple power system, that is a two machine equivalent.
- What supply voltage do we pick?
- From St. Clair we see that at 125 km, we can transfer 2.25 times SIL.
- From the table of SIL: 100 MW is twice SIL at 138 kV and approximately 75% of SIL at 230 kV.
- The question now becomes – what reactive support does the new load require?



REACTIVE POWER FLOW



Reactive Support

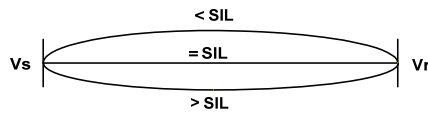

- At SIL, shunt capacitive energy equals series inductive energy.
- Below SIL there is an excess of shunt capacitive energy.
- Above SIL there is a deficiency of shunt capacitive energy.
- Sending and receiving ends have to supply the reactive energy.



Calculating Reactive Support

- Use the per unit (pu) system.
- Define SIL = 1 pu & Voltage = 1 pu.
- At SIL, current = 1 pu.
- At 1.5 SIL, current equals 1.5 pu.
- Series reactive energy = $\frac{1}{2} LI^2$
- Required reactive energy = 2.25 pu.
- Line supplies 1 pu.
- Therefore required reactive energy = 1.25 pu
- Voltages are equal, therefore $\frac{1}{2}$ VARs from each end.



345 kV, 200 km Line Example

- From the table, charging is 605 kVAr/km
- VArS at 1.5 SIL are:
 $200 \times 0.605 \times 1.5^2 = 272 \text{ MVAR}$
- VArS @ SIL = 120 MVAR
- Required VArS from each end = $(272 - 120)/2$
= 76 MVAR
- Two machine model has the capability
- Receiving end may require shunt capacitor bank, depends on system planning and design considerations for a single machine model.



CONDUCTOR SELECTION



Conductor Selection

- REA specifies minimum conductor sizes.
- Larger conductors at higher voltages required to minimize corona which is rich in harmonics.
- Electric field at conductor surface is minimized with a large conductor – larger surface area.
- Bundling, i.e. using more than one conductor per phase at higher voltages reduces onset of corona.
- Allows use of two smaller conductors.



CONDUCTOR RATINGS



Conductor Ratings

- IEEE 738-2006 defines rating of conductors.
- Based on modified House & Tuttle method.
- Four ratings – Summer, Winter, Operating and Thermal.
- Summer Thermal – conductor 100°C, ambient 40°C, wind 2 fps.
- Winter Thermal – conductor 100°C, ambient 0°C, wind 2 fps.
- Operating limits, based on 75°C conductor temperature with the same ambient conditions.
- Ambient temperatures are location dependent and utility operating experience.
- Wind speed is fixed!
- Rating includes orientation of the line, that is does it run north – south or east – west.
- In addition, latitude of the line is taken into account.



Transmission Line Conductor Ratings

Voltage (kV)	Conductor (MCM)	Summer Thermal MVA	Winter Thermal MVA	Summer Operating MVA	Winter Operating MVA
72	266	45	70	60	80
138	477	125	190	165	215
230 (single)	795	280	435	385	500
230 (bundled)	2x795	560	875	765	1000
345 (bundled)	3x795	1260	1970	1725	2255
500 (bundled)	4x795	2430	3800	3330	4360



LOSSES

© 2013 b7kennedy & Associates Inc.

33



Transmission Losses

- Because the X/R ratio for higher voltage lines is in the vicinity of 10, we have been able to ignore losses.
- However, losses are always there.
- Losses vary in relation to the line loading.
- Transmission lines have a long life – 35 to 50 years.
- It's important that the right conductor be chosen because the associated losses are paid every year.
- In addition, line loading is increasing every year.

© 2013 b7kennedy & Associates Inc.

34



Transmission Losses

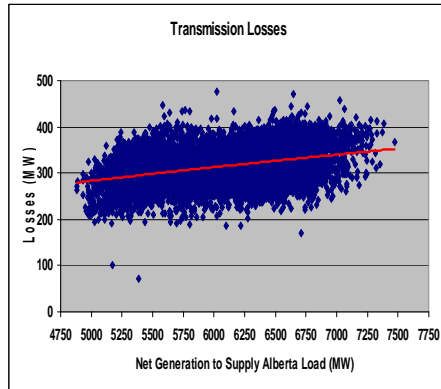

- Losses are variable or stochastic.
- Simple system – losses vary as a square of current.
- Complex system – losses display a linear variance.

© 2012 b7kennedy & Associates Inc.

35



Transmission Losses

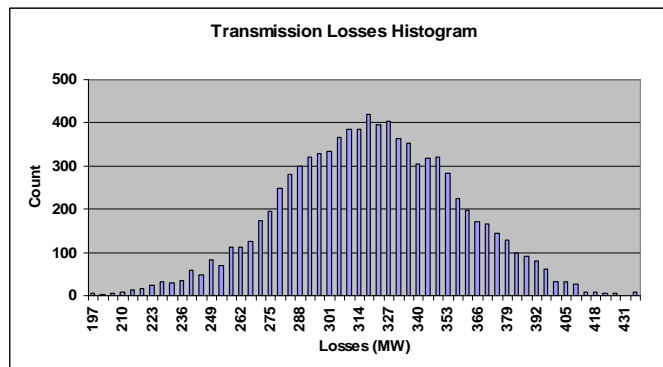

- Histogram demonstrates a normal distribution pattern for losses.

© 2012 b7kennedy & Associates Inc.

36



Losses on a Simple System

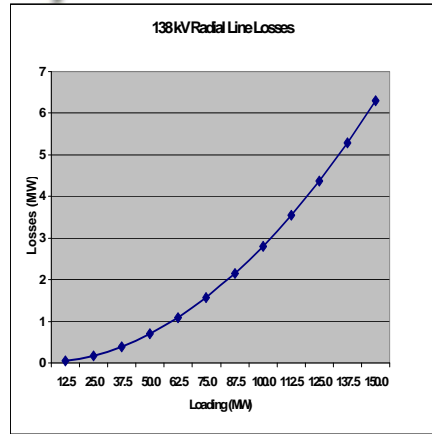

- Take a radial 138 kV line and load it up.
- Losses vary as the square of the current times the resistance of the line.



ECONOMIC CONDUCTOR SELECTION



Conductor Optimization

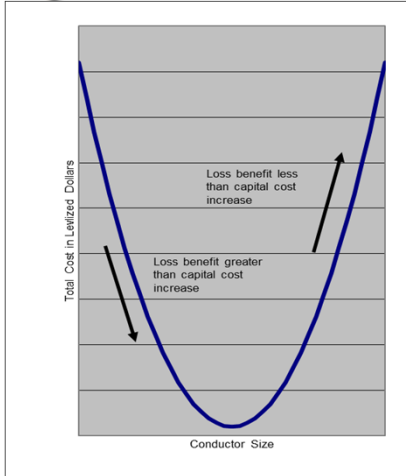

- Balance between capital cost and loss costs.
- Taken over lifetime of facility > 20 years.
- Total cost is the Present Worth Cost. That is costs are discounted back to a base year using inflation and interest rates and summed.
- Conductor optimization gives biggest conductor at lowest total cost.

© 2013 b7kennedy & Associates Inc.

39



Supply - Demand Curve

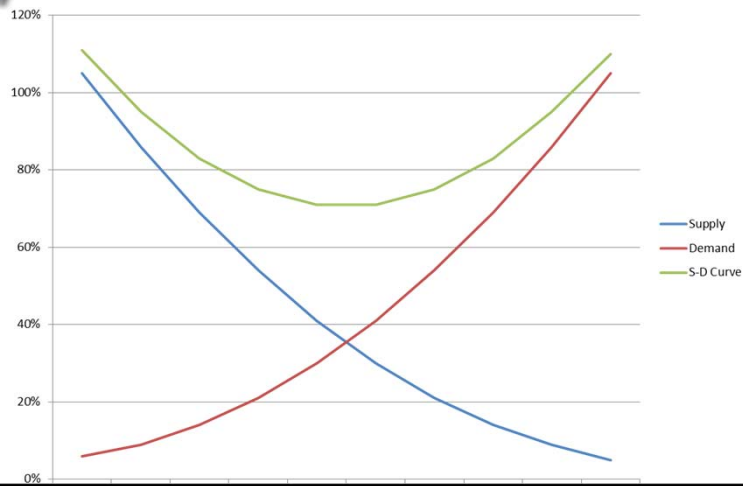

© 2013 b7kennedy & Associates Inc.

40



VOLTAGE AND ANGLE



Voltage and Angle

- We know that active power is closely coupled to the angle between voltage sources.
- For this reason we can transfer large amounts of active power over great distances.
- We also know that reactive power is closely coupled to the difference in voltage magnitudes.
- However, the differences in voltage magnitudes is limited to 5%.
- As a result it's not possible to transmit large amounts of reactive power over the power system.
- Reactive should generated and consumed where it's needed.

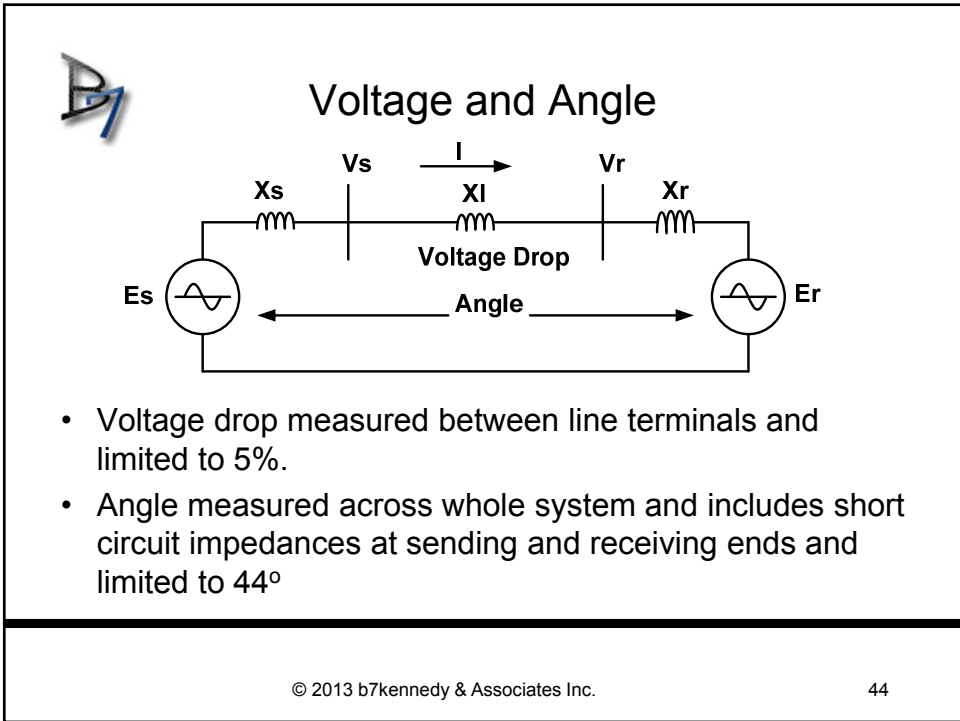
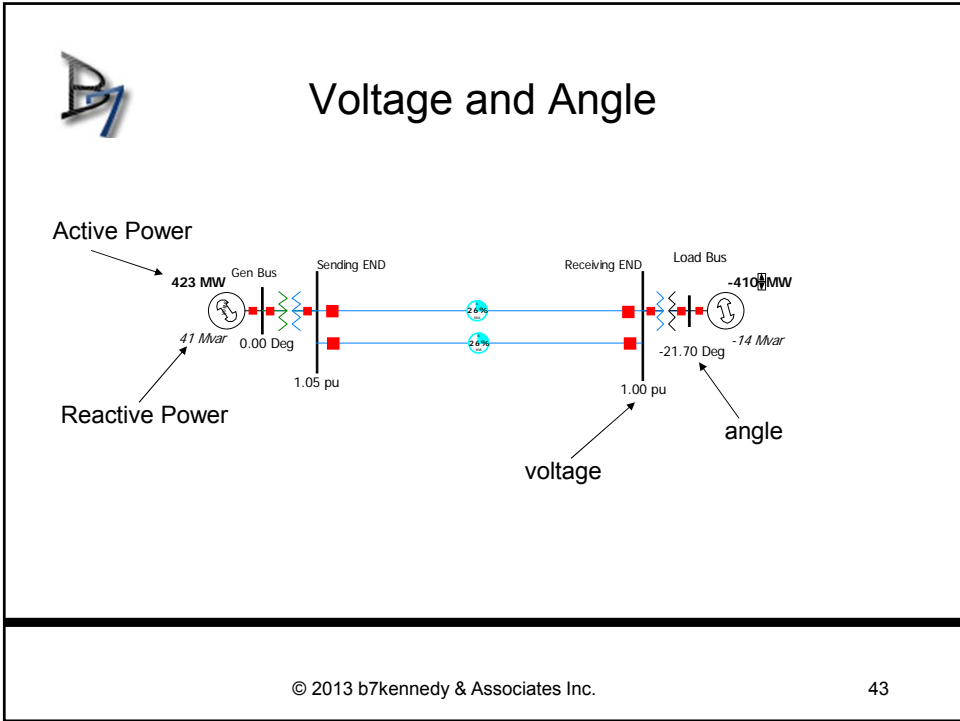



Sending and Receiving Voltages

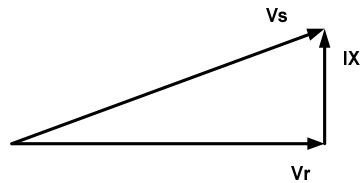

- 230 kV, 175 km line
 - Load is $1\frac{1}{2}$ SIL = 282 MW
 - $V_r = 230/\sqrt{3} = 133$ kV
 - $I = 282/(\sqrt{3} \times 230) = 0.708$ kA
 - $X = 175 \times 0.4 = 70$ Ω
 - $IX = 0.708 \times 70 = 49.6$ kV
 - $V_s = \sqrt{(133^2 + 49.6^2)}$
 - $V_s = 142$ kV
 - $\delta = \tan^{-1}(49.6/133) = 20.5^\circ$
- Use V_r as reference
 - Load is at unity power factor
 - V_r and I are in phase

© 2013 b7kennedy & Associates Inc.

45



Line Angle

- What is the angle across a line or system?
- How do you calculate it?
- Use the telegraph or long line equations.
- Find $\alpha + j\beta$
- Attenuation constant = α
- Phase constant = $j\beta$
- Phase constant is in radians/km.
- Convert to δ or degrees.
- Want a simpler method.

© 2013 b7kennedy & Associates Inc.

46



Line Angle

- Want a short cut method for calculating the angle across a system or section of a system.
- In a 60 Hz system, the system goes through 21,600 degrees in 1 second.
- Energy travels across the system at the speed of light.
- The speed of light is 3×10^5 km/sec.
- Therefore: system angle changes at 0.072 °/km.
- This is true at SIL of the system.
- Varies approximately in proportion to ratio of line loading to SIL.

© 2013 b7kennedy & Associates Inc.

47



Angle Across the Transmission Line

- Interested in calculating the angle between V_s & V_r .

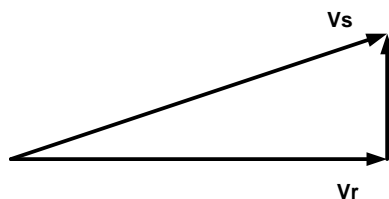

- Speed of light
 $c = 3 \times 10^5$ km/sec.
- In one second on a 60 Hz system 21,600°
- Dividing c into the degrees gives the constant 0.072°/km.
- Proportional to SIL.
- $\delta = 0.072 \times 175 \times 1\frac{1}{2} = 19^\circ$

© 2013 b7kennedy & Associates Inc.

48



MAXIMUM POWER TRANSFER

© 2013 b7kennedy & Associates Inc.

49



Maximum Power Transfer

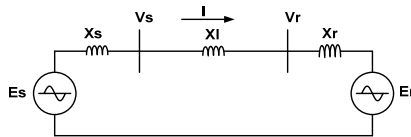

- $P = \text{Re} (E_s^* I)$
- Note: correct way is:
 $P = \text{Re} (E_s I^*)$

$$I = \frac{E_s(\delta) - E_r}{j(X_s + X_l + X_r)}$$

$$P = \text{Re} \left(\frac{E_s(-\delta)E_s(\delta)}{j(X_s + X_l + X_r)} - \frac{E_s(-\delta)E_r}{j(X_s + X_l + X_r)} \right)$$

$$P = \frac{E_s E_r}{X} \sin \delta$$

© 2013 b7kennedy & Associates Inc.

50



Maximum Power Transfer

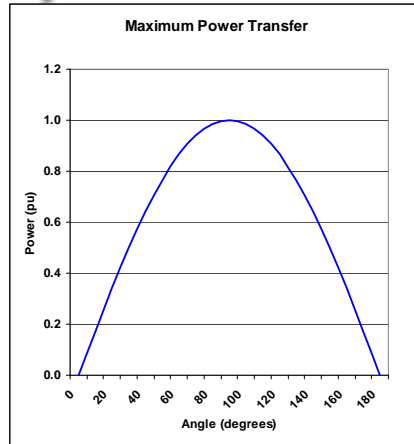

- Steady State Stability Margin
- Typical value = 44°
- 70% power transfer
- Margin = 30%
- Calculated:
 $\{(100 \times (1 - 0.7) / 1)\}\%$



Stability – text book basics

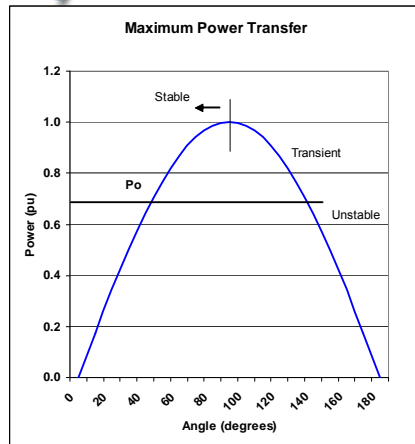

- P_o is the operating point.
- Typical value = 44° @ 70% power transfer.
- < 90° stable region.
- > 90° & < 135° transient region.
- > 135° unstable region.



APPLICATION EXAMPLE

© 2013 b7kennedy & Associates Inc.

53



Application Example

- Let's conclude with an application.
- You're in the field, testing a 345 kV breaker.
- You're finished for the day, and discover the 345 kV breaker won't close.
- You trace the problem to the synchronizing check relay required for closing the breaker.
- What do you do?

© 2013 b7kennedy & Associates Inc.

54



Ferranti Effect

- Open circuit voltage rise at the receiving end.
- Can be worked out from first principles.
- Travelling wave theory is best method.
- Voltage rise equal to the inverse of the cosine of the line angle.
- Open end voltage rise on 230 kV, 250 km line is:

$$V_{rise} = \frac{1}{\cos(250 \times 0.072)} = 1.05 \text{ pu}$$



Synch Check

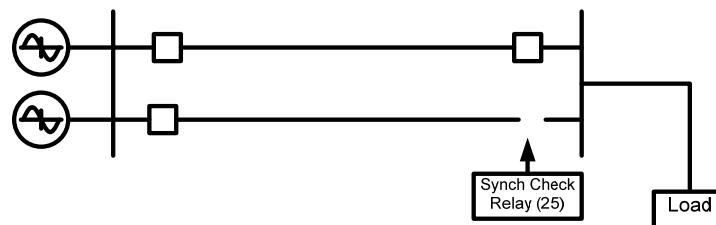

- Open 345 kV breaker won't close.
- Problem traced to Synch Check Relay – won't allow breaker to close.
- Want to check the Synch Check Relay setting at open breaker.



Synch Check

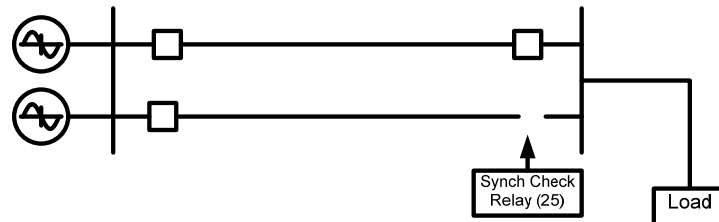

- 345 kV parallel line 200 km in length each carrying SIL.
- With one line open, other line carries 2 SIL.
- Angle is 29° .

© 2013 b7kennedy & Associates Inc.

57



Synch Check

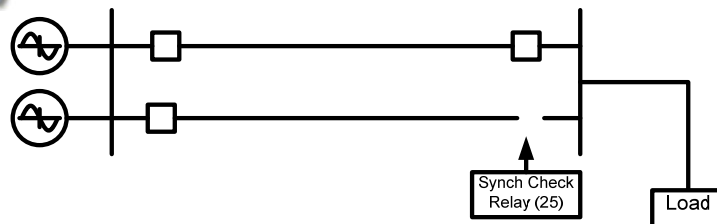

- Design allows maximum voltage drop of 10%.
- Actual voltage drop is 12%.
- Open circuit voltage rise is 1.03 pu.
- Voltage difference across open breaker is 0.15 pu.

© 2013 b7kennedy & Associates Inc.

58



Synch Check

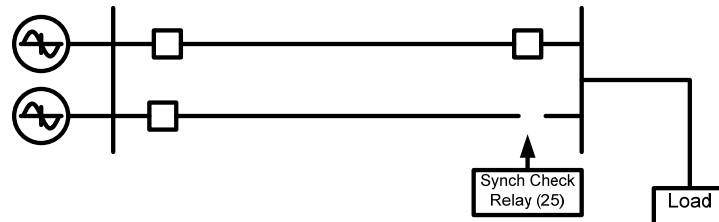

- Expected relay setting would be minimum angular difference of 30° and minimum voltage difference of 15%.
- You discover relay is set at 40° and 10% voltage difference.



Power of These Methods

- Assuming you become a power system engineer.
- Given a computer with up to \$75k worth of very powerful software.
- Your supervisor will tell you – play with the system!
- Test it against NERC Criteria.
- How do know you're getting the right answer?



NERC Requirements

- Category A – all facilities in service, system must be stable.
- That is no voltage violations and no equipment overloaded.
- Category B – one piece of equipment out of service, system must be stable.
- Category C – two pieces out of service, system must be stable.
- Category D – three or more pieces out of service, load and or generator shedding, system must return to stable state.



Cautionary Note ...

- Understand these methods before you use them.
- Short cut methods are no substitute for detailed power flow and fault studies
- Can and should be used before you start your work!
- Can be used to validate your studies!
- Develop your own numbers for the SIL table as each power system is a little bit different.



Transmission Line Summary

- Natural or SIL is an important property of transmission lines.
- SIL varies as the square of the line voltage.
- St. Clair Curve shows loading is related to distance.
- Overhead lines are most common for long distance transmission.
- Reactive power requirements vary as the loading of the line.
- Minimum conductor sizes dictated by corona.
- Standards dictate maximum loading of conductor.
- Transmission losses are fixed once conductor chosen.



That's all folks!



- Discussion
- Questions